



Proposed SHD at Auburn, Malahide Road

Planning Stage – Structural Report

March 2022

Waterman Moylan Consulting Engineers Limited

Block S, East Point Business Park, Alfie Byrne Road, Dublin D03 H3F4
www.waterman-moylan.ie

Proposed SHD at Auburn, Malahide Road

Planning Stage – Structural Report

Client Name: Kinwest Limited

Document Reference: 19-020r.011

Project Number: 19-020

Quality Assurance – Approval Status

This document has been prepared and checked in accordance with
Waterman Group's IMS (BS EN ISO 9001: 2015 and BS EN ISO 14001: 2015)

Issue	Date	Prepared by	Checked by	Approved by
1	01.03.2021	F. Atzei	D. Kelly	R. Osborne
2	31.03.2021	F. Atzei	D. Kelly	R. Osborne
3	22.10.2021	D. Kelly	R. Osborne	R. Osborne
4	24.03.2022	D. Kelly	R. Osborne	R. Osborne

Comments

Disclaimer:

This report has been prepared by Waterman Moylan, with all reasonable skill, care and diligence within the terms of the Contract with the Client, incorporation of our General Terms and Condition of Business and taking account of the resources devoted to us by agreement with the Client.

We disclaim any responsibility to the Client and others in respect of any matters outside the scope of the above. This report is confidential to the Client and we accept no responsibility of whatsoever nature to third parties to whom this report, or any part thereof, is made known. Any such party relies on the report at its own risk.

Our Markets



Property & Buildings



Transport & Infrastructure



Energy & Utilities



Environment

Content

1. Introduction.....	1
1.1 Scope	1
2. Site Constraints	2
2.1 Site Access	2
2.2 Traffic Management	2
2.3 Adjacent residential Properties	3
3. Structural Concept	4
3.1 Substructures.....	4
3.1.1 Foundations for typology 1 and 2	5
3.1.2 Basement Structure for typology 1	6
3.1.3 Basement Waterproofing for typology 1	6
3.1.4 Foundations for typology 3.....	7
3.2 Superstructures.....	7
4. Construction Methodology.....	10
4.1 Foundations Type 1	10
4.2 Foundations Type 2	10
4.2(A) Foundations Type 2 for Blocks 6 & 7.....	10
4.3 Foundations Type 3	10
4.4 Pumping Station.....	11
4.5 Measures to Protect Adjacent/Nearby Structures	11
5. Fire Protection of the Structures	12
6. Proposed Loadings	13
6.1 Design Loadings and Service Movements	13
6.1.1 Vertical Loads	13
6.1.2 Horizontal Loads	13
6.1.3 Service Movements	13
6.1.4 Loading Table (Subject to Final Confirmations of Superstructure).....	13

1. Introduction

1.1 Scope

Waterman Moylan has been appointed by Kinwest Ltd. to provide Structural Consultancy Services for the proposed strategic housing development at Auburn, Malahide, Co. Dublin and to develop the scheme to Planning Stage.

The following provides a summary of the advice and encapsulates the information gathered thus far.

The main structural issues covered are as follows:-

- Develop an understanding of site constraints.
- Form of the new structures.
- Advise structural dimensions.
- Review of construction methodology in relation to the site constraints

2. Site Constraints

The site is located between the existing Abington residential development and the Malahide Road. The site entrance is from the Malahide Road, adjacent to the Malahide Road/Back Road junction.

The subject lands form the western, northern, and eastern boundaries of Auburn House, an eighteenth century three-storey mansion located within a wooded demesne. Malahide Castle is approximately 900m north-east of the site.



Figure 1 | Site Location (Source: Google Maps)

A topographic survey of the area indicated that the site is very flat with only local high points. The site lies generally at a level of between 9m and 11m OD Malin, with a local high point near the north-east of the site of 12.45m OD Malin.

The site is relatively constrained with:

- Malahide Road
- Streamstown Lane
- Carey's Lane
- Adjacent Residential Properties (Abington/Carey's Lane)



Figure 2 | Proposed site plan (source CCK Architects)

2.1 Site Access

The site will be primarily accessed by a proposed signalised junction, at the junction of the Malahide and Back Roads. A secondary access will be accessed from Streamstown Lane and Carey's Lane.

2.2 Traffic Management

Construction timings and methods, protection and potential temporary detours for both pedestrians and vehicles shall be studied prior to the commencement of construction activities. The Contractor shall agree and submit proposals to Fingal County Council for approval.

2.3 Adjacent residential Properties

The site is adjacent to several residential properties (Abington Residential development and Carey's Lane). Dilapidation surveys will need to be undertaken to these properties ahead of the works commencing, in addition to monitoring of noise and vibration during demolition and construction.

Adjacent proposed Blocks 6 & 7 there is a protected Walled Garden Structure which has been considered in the design of the substructure for the block in order to minimise vibration and construction associated risks.

3. Structural Concept

The structural scheme has been developed following review of the architectural planning drawings and analysis of floor spans and structural zones.

The structural concept varies between the different building typologies proposed for the development. Below is a table summarising the structures across the development.

Building	Description
<u>Apartment Block 1</u>	Three and four storeys apartment block with landscaped courtyard over a shared basement (Blocks 1,2, & 3 Share a basement).
<u>Apartment Block 2</u>	Three and four storeys apartment block with a set back penthouse (five storey total)with landscaped courtyard over a shared basement (Blocks 1,2, & 3 Share a basement).
<u>Apartment Block 3</u>	Three and four storeys apartment block with landscaped courtyard over a shared basement (Blocks 1,2, & 3 Share a basement).
<u>Apartment Block 4</u>	Three storey apartment block with a set back penthouse (four storey total) with a shared landscaped podium with undercroft parking.
<u>Apartment Block 5</u>	Three and four storeys apartment block with a set back penthouse (five storey total) with a shared landscaped podium with undercroft parking.
<u>Duplex Apartment Block 1</u>	Two storey ground floor duplex unit with single storey apartment above. (Three storey total).
<u>Duplex Apartment Block 2 (A, B, C, D)</u>	Single storey ground floor own door unit, with two storey duplex units accessed from the podium above (three storeys total).
<u>Apartment Block 6</u>	Three storey apartment block with a set back penthouse (four storey total).
<u>Apartment Block 7</u>	Three and Four storeys apartment block with a set back penthouse (five storey total).
<u>Houses</u>	Semi-detached and detached units

Table 2 | Proposed buildings

3.1 Substructures

From an analysis of the anticipated building loads and the soil conditions described in the preliminary site investigation report, the proposed buildings have been divided in three different substructure typologies.

Building	Description	Substructure Typology	Description
<u>Apartment Block 1</u>	Three and four storeys apartment block with landscaped courtyard over a shared basement (Blocks 1,2, & 3 Share a basement).	Type 1	Basement Walls and columns over pilecaps, piles and ground beams
<u>Apartment Block 2</u>	Three and four storeys apartment block with a set back penthouse (five storey total)with landscaped courtyard over a shared basement (Blocks 1,2, & 3 Share a basement).	Type 1	Basement Walls and columns over pilecaps, piles and ground beams
<u>Apartment Block 3</u>	Three and four storeys apartment block with landscaped courtyard over a shared basement (Blocks 1,2, & 3 Share a basement).	Type 1	Basement Walls and columns over pilecaps, piles and ground beams
<u>Apartment Block 4</u>	Three storey apartment block with a set back penthouse (four storey total) with a shared landscaped podium with undercroft parking.	Type 2	Pilecaps, piles and ground beams under load bearing walls and columns.
<u>Apartment Block 5</u>	Three and four storeys apartment block with a set back penthouse (five storey total) with a shared landscaped podium with undercroft parking.	Type 2	Pilecaps, piles and ground beams under load bearing walls and columns.
<u>Duplex Apartment Block 1</u>	Two storey ground floor duplex unit with single storey apartment above. (Three storey total).	Type 3	Reinforced Concrete Strip Footings under load bearing walls
<u>Duplex Apartment Block 2 (A, B, C, D)</u>	Single storey ground floor own door unit, with two storey duplex units accessed from the podium above (three storeys total).	Type 2	Pilecaps, piles and ground beams under load bearing walls and columns.

<u>Apartment Block 6</u>	Three storey apartment block with a set back penthouse (four storey total).	Type 2*	Pilecaps, piles and ground beams under load bearing walls and columns
<u>Apartment Block 7</u>	Three and Four storeys apartment block with a set back penthouse (five storey total).	Type 2*	Pilecaps, piles and ground beams under load bearing walls and columns
<u>Houses</u>	Semi-detached and detached units	Type 3	Reinforced Concrete Strip Footings under load bearing walls

*Foundations in proximity to protected Walled Garden. Refer to Section 4.2(A) for methodology.

3.1.1 Foundations for typology 1 and 2

The soil conditions and anticipated building loads would require piled foundations. The proposed piles are to be conventional continuous flight auger (CFA) or rotary bored piles of 750mm diameter, subject to a site investigation, and will be designed to resist the vertical and horizontal loads from the structure above.

CFA piles are proposed for Blocks 6 & 7 due to the low-vibration method of construction to limit risks of vibration to the nearby protected walled garden structures. There is no basement under Blocks 6 & 7 meaning that excavations are limited to the depths of the pile caps and ground beams.

Rectangular reinforced concrete beams (Ground Beams) will span between pilecaps to support load bearing walls.

Pile caps will be reinforced concrete cast in-situ elements designed to spread the building loads into the piles. The pile caps are typically 1000 to 1800mm deep for 750mm diameter piles

- Typical Pile Cap dimension*: 2500x2500x1800mm deep square pilecap under columns.
- Typical Ground Beam dimension*: 700x900mm deep spanning between pilecaps.

Note: Dimensions shown above are typical of what will be requires but may be subject to change when more detailed Ground Investigation information or other information on site conditions becomes available.

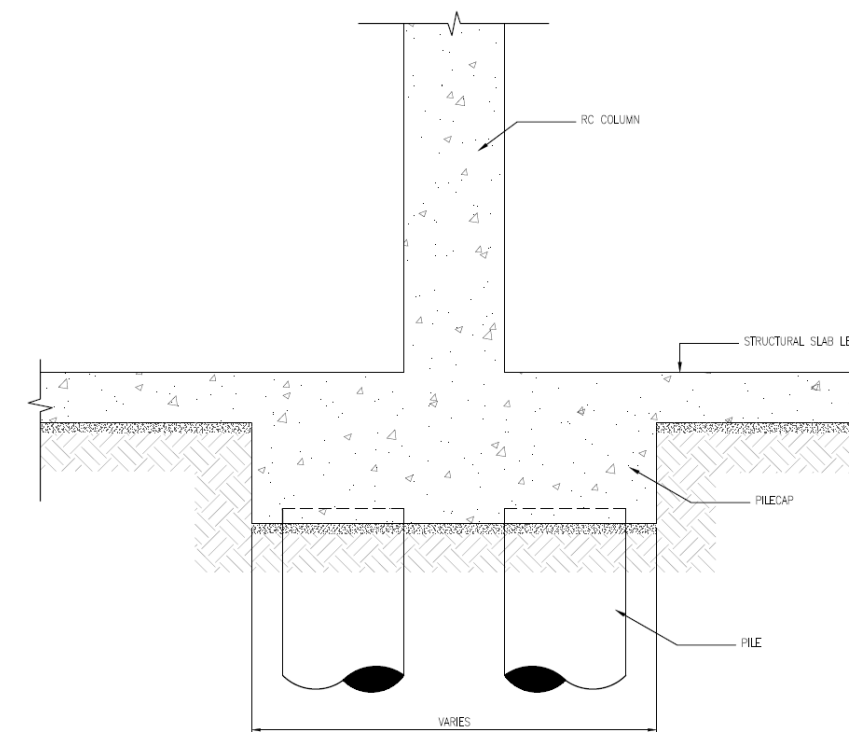

Typical Foundation Type 1 and 2

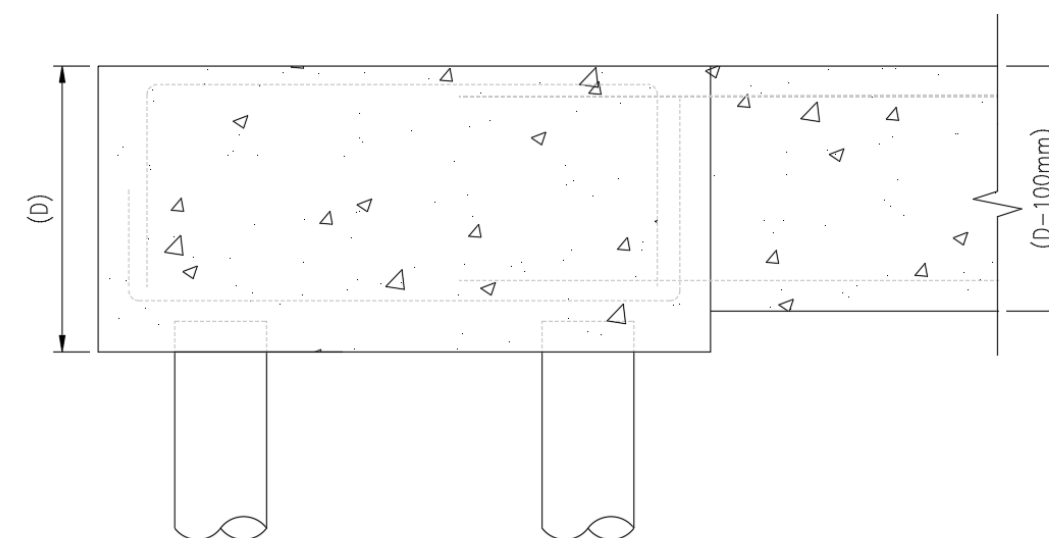

Typical Pilecap-Groud Beam Interface

3.1.2 Basement Structure for typology 1

The perimeter of the basement will be constructed using reinforced concrete walls, 250-300mm thick.

Clear height within the basement will be 3 meters under Blocks 2 and 3, and 3.4 meters under Block 1.

Podium slab will slope between Blocks 2 and 3 and the finished floor level of the buildings above steps 400mm between each block. Refer to CCK Drawing nr. 1920 P 300 for further details.

Note: The basement footprint will not encroach on any tree root protection area.

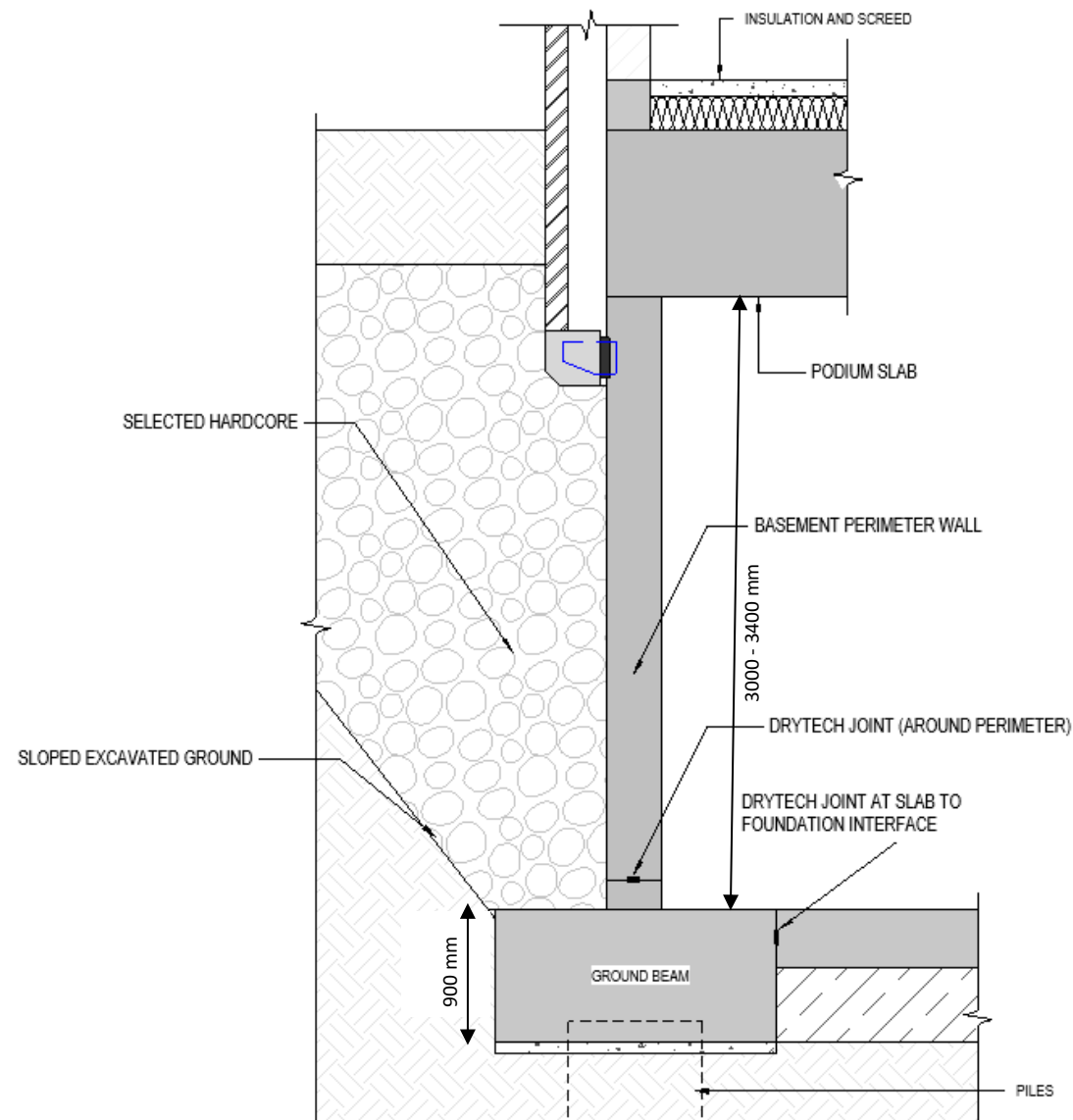

Typical Basement Wall

3.1.3 Basement Waterproofing for typology 1

Requirement and details for basement waterproofing are shown by the Architect.

Table 2 Grades of waterproofing protection

Grade	Example of use of structure ^{A)}	Performance level
1	Car parking; plant rooms (excluding electrical equipment); workshops	Some seepage and damp areas tolerable, dependent on the intended use ^{B)} Local drainage might be necessary to deal with seepage
2	Plant rooms and workshops requiring a drier environment (than Grade 1); storage areas	No water penetration acceptable Damp areas tolerable; ventilation might be required
3	Ventilated residential and commercial areas, including offices, restaurants etc.; leisure centres	No water penetration acceptable Ventilation, dehumidification or air conditioning necessary, appropriate to the intended use

^{A)} The previous edition of this standard referred to Grade 4 environments. However, this grade has not been retained as its only difference from Grade 3 is the performance level related to ventilation, dehumidification or air conditioning (see BS 5454 for recommendations for the storage and exhibition of archival documents). The structural form for Grade 4 could be the same or similar to Grade 3.

^{B)} Seepage and damp areas for some forms of construction can be quantified by reference to industry standards, such as the ICE's *Specification for piling and embedded retaining walls* [1].

Grades of Waterproofing Protection (extract from BS8102:2009)

In basement habitable areas, core lobbies, electrical rooms and lift-pits, the basement waterproofing performance will need to be BS 8102:2009 Grade 3. Elsewhere the basement will be designed for Grade 2.

Current proposals to achieve this required environment will be developed over the next stage. At this stage and for any preliminary cost plans we would suggest that a "white tank" system by Rascor or Drytech is considered.

3.1.4 Foundations for typology 3

From the anticipated soil conditions, it is expected that the structure will be supported on shallow foundations. This will comprise in reinforced concrete strip footings on mass concrete (leanmix) extending to the stiffer ground layers where necessary.

The ground floor slabs are 150mm thick reinforced concrete and ground bearing. The slabs are formed on 50mm T3 Blinding with minimum 225mm T2 hardcore to SR:21 requirements.

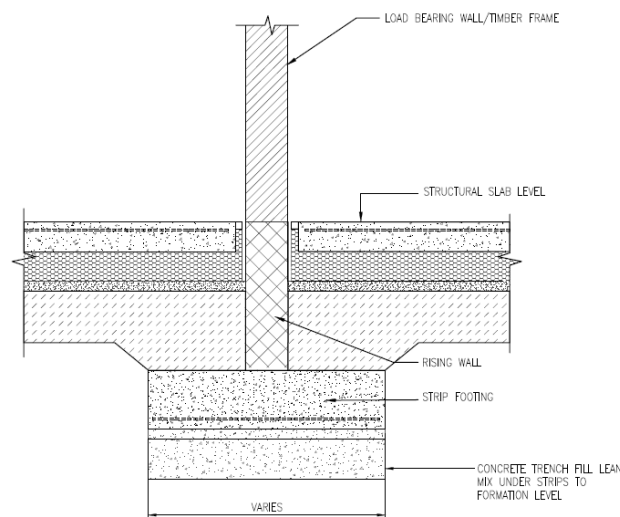

Typical Foundation Type 3

- Semi Detached Houses Typical Strip Footings: 900 to 1500mm wide by 300mm deep*.
- Duplex Apartment Blocks Typical Strip Footings: 900 to 1800mm by 300mm deep*.

Note: Dimensions shown above are typical of what will be requires but may be subject to change when more detailed Ground Investigation information or other information on site conditions becomes available.

3.2 Superstructures

A material options study for the super-structure was undertaken for all the proposed building typologies and can be summarised as follows.

Houses and Duplex Apartment Blocks					
	Framing Layout	Speed-of-Construction	Fire Resistance	Acoustic Performance	Vibration Performance
Masonry Walls & Precast Concrete	Average	Average	Good	Good-Average	Good
Timber Frame	Good	Good	Average	Average	Average
Masonry Walls & Timber Floors	Good	Average	Average	Average	Average

For the houses it is proposed to use either Masonry Walls and Timber Floors (Traditional build) or Timber Frame for the superstructure.

For the duplex apartment blocks, it is proposed to use Masonry Walls & Precast Floors for the superstructure, or a combination of Masonry Walls and Precast Floors for the ground floor unit and Timber Frame or Traditional Build for the unit above.

Apartment Blocks					
	Framing Layout	Speed-of-Construction	Fire Resistance	Acoustic Performance	Vibration Performance
Hybrid Precast Hollowcore & Crosswalls	Good	Good	Good	Good-Average	Good
In-situ Concrete Frame	Good	Poor	Good	Good	Good
Steel Frame & Precast Concrete	Good	Good	Average	Good-Average	Average
Masonry Walls & Precast Concrete	Poor	Poor	Good	Good-Average	Good

Block 1, 2 and 3: The proposed structure is to be an in-situ reinforced concrete frame due to the size and geometry of the blocks. This structure type will be overall lighter compared to precast wall or masonry wall structure and provides greater flexibility in reducing areas of transfer and to achieve the architectural intent.

Block 4 and 5: The proposed structure is to be an in-situ reinforced concrete frame due to the size and geometry of the blocks. This structure type will be overall lighter compared to precast wall or masonry wall structure and provides greater flexibility in reducing areas of transfer and to achieve the architectural intent.

Block 6 and 7: The proposed structure is to be an in-situ reinforced concrete frame due to the size and geometry of the blocks. This structure type will be overall lighter compared to precast wall or masonry wall structure and provides greater flexibility in reducing areas of transfer and to achieve the architectural intent.

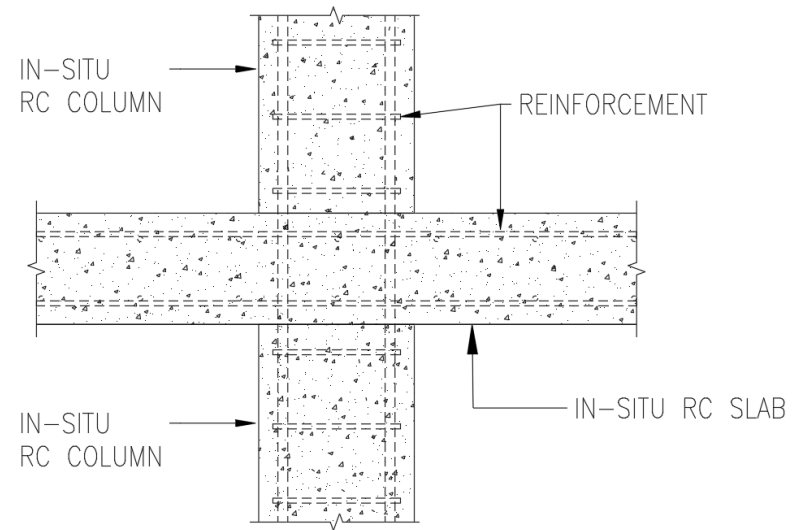

Typical In-Situ Reinforced Concrete Floor Structural Build-up

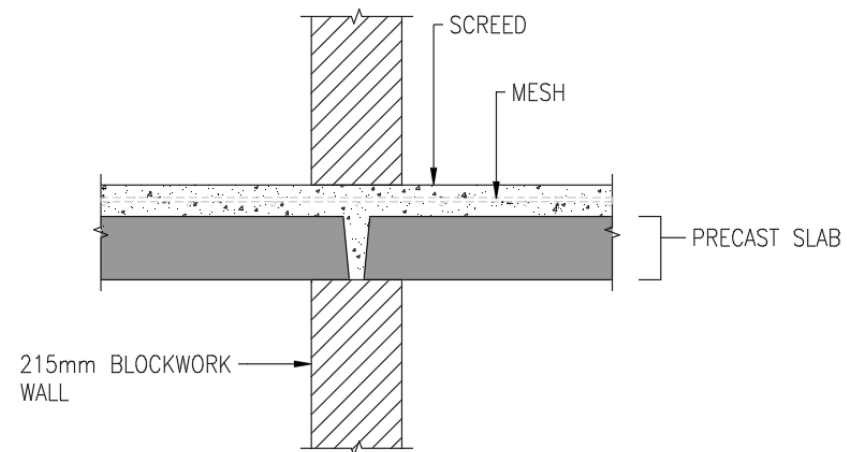

Typical Masonry Walls & Precast Concrete Floor Structural Build-up

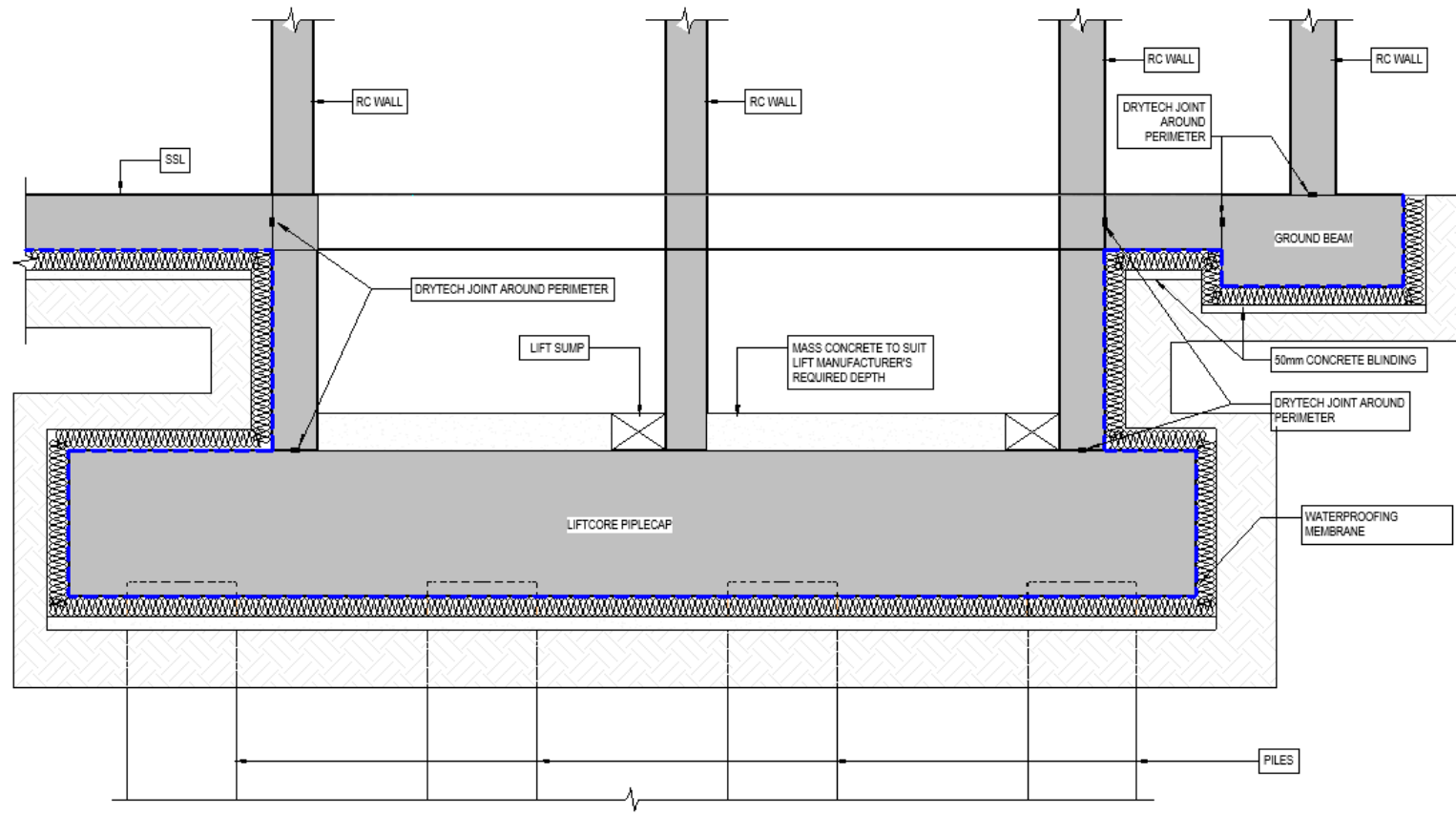

Typical Lift Pit
(In-Situ RC Frame Superstructure)



Typical Lift Pit
(Masonry Walls & Precast Concrete Floor Superstructure)

4. Construction Methodology

4.1 Foundations Type 1

The sequence of works for the construction of the basement will be as follows:

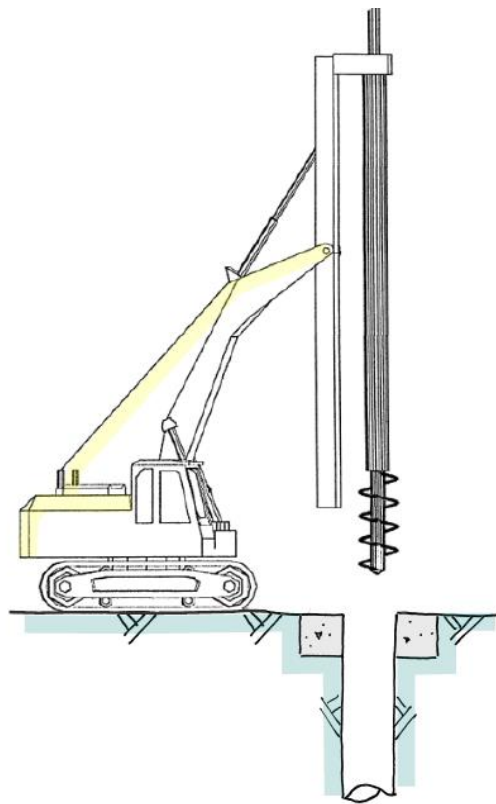

Typical Piling Installation

- Excavate basement, secure excavation & Install Temporary Works (if required).
- Install Piling Mat & Temporary guide wall (if required)
- Install Piles
- Construct RC Ground Beams and Pile Caps
- Construct Basement RC Slab
- Construct Basement RC Walls and Columns
- Construct Podium Slab

4.2 Foundations Type 2

The sequence of works for the construction of the type 2 foundations will be as follows:

- Excavate to foundation level
- Install Piling Mat & Temporary guide wall (if required)
- Install Piles
- Construct RC Ground Beams Beams and Pile Caps
- Construct masonry/concrete rising elements over the pile caps and ground beams.
- Place and compact approved granular fill to the underside of ground floor slab
- Construct RC Ground Floor Slab

4.2(A) Foundations Type 2 for Blocks 6 & 7

The sequence of works for the construction of the type 2 foundations for Blocks 6 & 7 will be as follows:

- Condition Survey of nearby Protected Walled Garden to be undertaken
- Vibration Monitoring stations to be set up (agreed with adjacent Owners/Consultants)
- Excavate to foundation level (FFL of Block 7 is ~700mm above existing ground levels, as a result excavations for this block will be less deep than elsewhere thus minimising risks)
- Install Piling Mat
- Install Piles (CFA to limit vibrations)
- Construct RC Ground Beams Beams and Pile Caps
- Construct masonry/concrete rising elements over the pile caps and ground beams.
- Place and compact approved granular fill to the underside of ground floor slab
- Construct RC Ground Floor Slab

4.3 Foundations Type 3

The sequence of works for the construction of the type 3 foundations will be as follows:

- Excavate to formation level
- Place lean mix to reach foundation level (if required)
- Construct RC Strip footings
- Construct masonry rising walls
- Place and compact approved granular fill to the underside of ground floor slab
- Construct RC Ground Floor Slab

4.4 Pumping Station

An underground pumping station with a 186 m³ storage tank will be constructed to the south-east of the site as detailed in 19-020-P206.

The tank will be constructed in cast in-situ reinforced concrete.

Foundations will consist of a 450mm thick cast in-situ raft foundation with thickenings under reinforced concrete walls and columns. Reinforced concrete walls are expected to be 300mm thick and top slab to be 350mm thick.

The sequence of works for the construction of the pumping station tank will be as follows:

- Excavate to formation level, secure excavation & Install Temporary Works.
 - o Sheet Piling (or similar) is proposed to protect tree roots to allow installation of the tank.
- Construct cast-in situ reinforced concrete raft foundation.
- Construct tank cast in-situ reinforced concrete boundary walls.
- Construct tank cast in situ reinforced concrete capping slab.
- Construct remaining cast in-situ reinforced concrete walls above the capping slab.

4.5 Measures to Protect Adjacent/Nearby Structures

The following measures have been considered in design over the Planning Stage to protect the adjacent structures:

- (1) The extent of basements footprint and depth of basement have been kept to a minimum.
- (2) The basements have been set-out and positioned away from the site boundaries. It is deemed that this is far enough away so that the zone of influence from the basement excavation will not affect the nearby buildings.
- (3) Driven piles shall not be used.
- (4) CFA Piling is proposed to minimise noise and vibration during the works.
- (5) The basement walls will provide a groundwater cut-off and prevent groundwater movement between the basement excavation and surrounding subterranean area. This will mitigate the risk of changes to the existing groundwater levels during construction (subject to the ground investigation and level of the existing groundwater).
- (6) Additional measures will be adopted by the Contractor during construction as per health and safety requirements and best practice.

5. Fire Protection of the Structures

It is currently understood that a 90-minute fire protection will be required generally for the apartments, with 120 minutes required for certain cores and escape routes, and 60 minutes for the houses and duplex apartment blocks, subject to the Fire Consultants Report.
240 minutes is required in electrical ESB substation rooms.

Fire protection to all concrete elements will be achieved as follows, as per IS EN 1992-2:

Core walls and Columns	-	RC concrete cover and minimum element dimensions
Horizontal members and hollowcore slabs	-	RC concrete cover and minimum element dimensions.
120 minute areas	-	RC concrete cover and minimum element dimensions.
240 minute areas	-	RC concrete cover and minimum element dimensions.

6. Proposed Loadings

6.1 Design Loadings and Service Movements

6.1.1 Vertical Loads

These comprise superimposed live loads [due to occupancy, plant, storage, etc.], superimposed dead loads [due to M&E services, etc.] and self-weight of structure plus cladding. Superimposed live loads and dead loads are listed below and the design takes into account structure and cladding self-weight.

6.1.2 Horizontal Loads

These comprise either wind loading on the building façade or “EHF – Equivalent Horizontal Forces” as defined in Eurocode. EHF loads occur due to lack of fit of the structure, etc. The combination of these two are used in the design in accordance with IS EN 1990.

6.1.3 Service Movements

Horizontal and vertical movements due to superimposed live loads and wind loads are limited to the following:

$$\text{Horizontal building sway [wind load]} = \frac{\text{height}}{500}$$

Vertical slab/beam deflections [superimposed live load]:

i] Floor beams = $\frac{\text{span}}{360}$

ii] Slab/Beam supporting cladding = $\frac{\text{span}}{500}$ or 10 mm whichever is less.

6.1.4 Loading Table (Subject to Final Confirmations of Superstructure)

A <u>Typical Apartment Floor</u>	
200 Precast Slab	3.00 kN/m ²
75mm Screed	1.80 kN/m ²
Floor Finishes	0.35 kN/m ²
Ceiling & Services	<u>0.25 kN/m²</u>
	5.40 kN/m ²
Imposed load (Class A2) [Including 1.0kN/m ² partitions]	3.0 kN/m ²

B <u>Typical Podium (Building Footprint)</u>	
750 normal weight slab	18.75 kN/m ²
Finishes	0.50 kN/m ²
75mm Screed (2000kg/m ³)	1.50 kN/m ²
Floor insulation	0.05 kN/m ²
Ceiling & services	<u>0.45 kN/m²</u>
	21.25 kN/m ²

imposed load (Class A2)
[Including 1.0kN/m² partitions] 3.0 kN/m²

C <u>Typical Podium (Landscaped Area)</u>	
550 normal weight slab	13.75 kN/m ²
Landscaping (TBC)	10 kN/m ²
Waterproofing	0.5 kN/m ²
Insulation	0.20 kN/m ²
Ceiling & Services	<u>0.45 kN/m²</u>
	24.9 kN/m ²

Imposed load (Vehicle Access) 10 kN/m²

D <u>Roof Areas</u>	
200 Precast Slab	3.00 kN/m ²
75mm Screed	1.80 kN/m ²
Sedum	3.00 kN/m ²
Waterproofing	0.30 kN/m ²
Insulation	<u>0.20 kN/m²</u>
	8.30 kN/m ²

imposed load (MEP) 7.5 kN/m²
Imposed load (PVs) 3.0 kN/m²
Access/Maintenance 0.6 kN/m²

E <u>Corridor / Lobby Areas</u>	
200 Precast Slab	3.00 kN/m ²
75mm Screed	1.80 kN/m ²
Floor Finishes	0.35 kN/m ²
Ceiling & Services	<u>0.45 kN/m²</u>
	5.60 kN/m ²

Imposed load 5.0 kN/m²

F Disproportionate Collapse
The structure is in excess of five storeys and therefore will be checked for disproportionate collapse in accordance with IS EN 1991-1-7:2006 Annex A and Building Regulations.

Accidental loading at 34 kN/m² will be applied to "key elements", i.e. columns and beams carrying columns, and criteria in regard to perimeter ties and tying forces.

UK and Ireland Office Locations

